

# Mobile Column Lift for trucks and buses Model: RGE



Quality control and certification  
according to DIN EN ISO 9001



- ▶ 5-year warranty on lifting screw and nut
- ▶ Automatic synchronization
- ▶ Recirculating ball nut and screw (efficiency over 90 %)
- ▶ Electronic measurement by inductive sensors

Premium Workshop  
Equipment



- ▶ Automatic synchronization
- ▶ Per key click selection of individual posts (Group formation)
- ▶ Individual power unit (no master column)
- ▶ Low-friction recirculating ball nut and screw (efficiency over 90 %)
- ▶ Low power consumption (only 1.5 kW per column)
- ▶ Fuse protection: only 16 amps for 4 columns
- ▶ Slim, versatile column design
- ▶ Columns weigh only 400 kgs
- ▶ Easy to operate
- ▶ Long life expectancy
- ▶ High safety level ensured by independent locking device
- ▶ Manual lowering function
- ▶ Quick and easy interconnection of columns
- ▶ Electronic measurement by inductive sensors

**Lifting system:**

Hardened stainless steel screw with low friction recirculating ball nut. Splash proof and dirt repellent design giving long life and low maintenance.



**Safety system:**

Independent locking device acting directly between column and carriage.

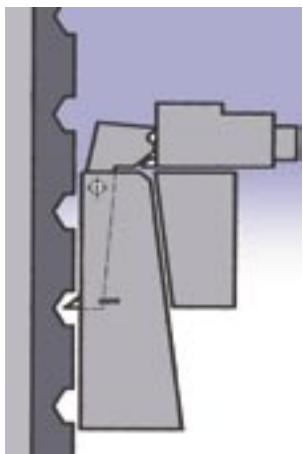

Option: Hydraulic

MAHA with over 30 years of lifting experience has designed the ultimate in mobile column lifts. The RGE series with microprocessor control features the following functions:

- ▶ Automatic synchronization and communication between columns
- ▶ Group operation of six or eight posts available
- ▶ LED self-diagnosis
- ▶ Electronic shut down if obstruction detected
- ▶ Electronic measurement by inductive sensors
- ▶ Monitoring and automatic correction of phase sequence



Light & slim design giving easy manoeuvrability when loading and unloading.



Remote Control (Optional)



Convenient operation using sturdy key pad ( up, down, single and group operation possible)



Mobile power supply unit, no master column.



Lighting at each column

## All features at a glance:

- ▶ Mobile power supply unit, no master column
- ▶ Automatic synchronization and communication between columns
- ▶ Recirculating ball nut and screw (efficiency over 90 %)
- ▶ Electronic measurement by inductive sensors
- ▶ Easy handling ensured by slim design and low column weight (400 kg)
- ▶ Quick and easy interconnection of columns
- ▶ Independent locking safety device
- ▶ Universal Lift **RGE GPGU (VP 451064)** especially suited for forklifts and rail vehicles
- ▶ Customised systems available on request
- ▶ CE design certification

## Accessories:



Special carriage for super single tires.  
Fork length: 500 mm  
Load capacity: 7,500 kg

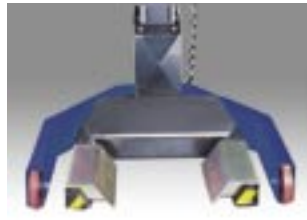

Reduction sleeves (EP 2) for smaller wheel diameters.



Stands:  
AB 6-07 Ad. range 570...800 mm  
AB 6-12 Ad. range 800...1250 mm  
AB 6-20 Ad. range 1300...2000 mm



Adjustable support SP 75  
Support plate APV  
Support disk APR

## Specifications:

Load capacity per column	7,5 t
Net weight per column	400 kg
Raising/Lowering time	113 s
Motor power per column	1,5 kW
Control voltage	220 / 24 V
Supply voltage	3 x 400 V + N + PE; 50 Hz
System of protection	IP 55

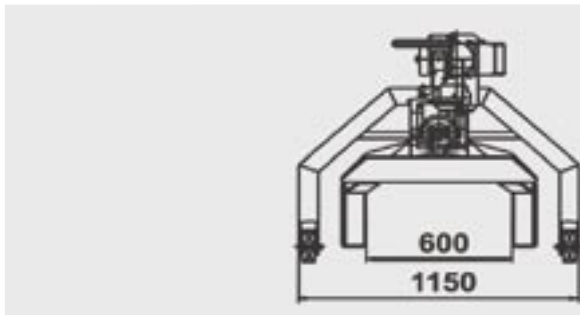
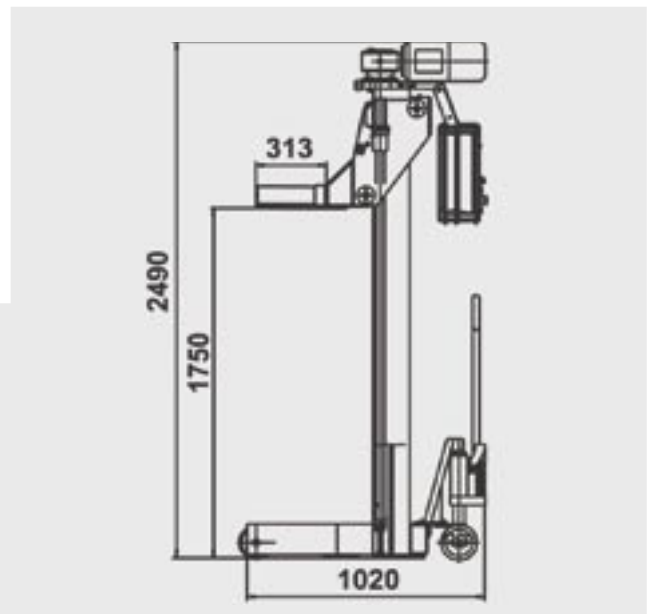

## Production Program:

Testing Technology for Cars, Trucks, Motorcycles, Tractors, Forklifts, Aircraft · Roller Brake Testers · Platform Brake Testers · Shock Absorber and Suspension Testers · Side-Slip Testers · Play Detectors · Roller Dynamometers for Performance and Function Testing · Speedometer Testers · Tachograph and Taximeter Testers · Axle and Wheel Load Scales · Scissors Lifts · Two- and Four-Post Lifts · In-Ground Lifts · Pit Jacks · Axle and Transmission Jacks · Mobile Column Lifts · Headlight Testers · Diesel Smoke Meters · Emission Testers for Petrol and Gas Engines · Sound Level Meters · Air Conditioning Service Equipment · Decelerometers · Closing Force Meters · Brake Fluid Testers · Complete Test Lanes for Cars and Trucks · Mobile Test Containers · Wheel Alignment Analysers · Wheel Balancers · Tyre Changers.

**Additional Services:** Workshop Design and Planning · Training Seminars for Users and Service Technicians



**MAHA Maschinenbau Haldenwang GmbH & Co. KG.**

Hoyen 20 · 87490 Haldenwang · Germany

Tel.: +49 (0)8374-585-0 · Fax: +49 (0)8374-585-497

Internet: [www.maha.de](http://www.maha.de) · eMail: [sales@maha.de](mailto:sales@maha.de)

- ▶ MAHA USA · Charleston SC · USA
- ▶ MAHA U.K. Ltd. · Wisbech · Great Britain
- ▶ MAHA Ireland Ltd. · Dublin · Ireland
- ▶ MAHA Italy SRL · Parma · Italy
- ▶ MAHA España · Girona · Spain
- ▶ MAHA Polska · Gliwice · Poland
- ▶ MAHA Russia · St. Petersburg · Russian Fed.

- ▶ MAHA LITA Bj. · Vilnius · Lithuania
- ▶ MAHA China · Peking · China
- ▶ MAHA Japan · Kitakyushu · Japan
- ▶ MAHA Consulting s.r.o. · Prague · Czech Republic
- ▶ MAHA Nederland B.V. · Vianen · The Netherlands
- ▶ MAHA France Distrib. · Strasbourg · France
- ▶ MAHA South Africa · Northcliff · Republic of South Africa

